



FEATURES

TWO MODELS:

UNIVERSAL BUCKS: PRE-U

BUCKS FOR COLLAR AND CUFF: PRE-CP

- Up steaming lower buck on both models.
- Lowering of the upper buck controlled by two push buttons.
- Available with or without built-in boiler.
- Available with or without built-in air compressor.
- All models equipped with a vacuum unit.
- ready to be connected to central steam and air supply.
- Air working pressure: 6-7 bar
- Steam working pressure: 4-5 bar
- Connection: 230/400V III 50-60Hz

PRESS PRE-U MODEL

- Utility buck, up-steaming lower buck and upper buck, optional polished upper buck.
- Board dimensions : 1.170 x 360 x 220 mm.

PRESS PRE-CP MODEL

- Collar & Cuffs bucks, up-steaming lower buck.
- Polished upper buck.



OPTIONS

- Built-in electric steam boiler 16 Litres (12 kW)
- Built-in air compressor 2 HP
- Group of iron + pedal
- Spray gun for steam
- Polished upper buck for laundry, not up-steaming (PRE-U model)

TECHNICAL DATA	UNIT.	PRE-U		PRE-CP	
		WITH BOILER	WITHOUT BOILER	WITH BOILER	WITHOUT BOILER
GENERAL DETAILS					
Board dimensions	mm	1.170 x 360 x 220	1.170 x 360 x 220	940 x 160	940 x 160
Boiler capacity	l	16	-	16	-
Compressor	-	Opt	Opt	Opt	Opt
Group of Iron	-	Opt	Opt	Opt	Opt
Steam gun	-	Opt	Opt	Opt	Opt
Polished upper buck	-	Opt	Opt	Opt	Opt
POWER					
Vacuum Motor	HP	0,6	0,6	0,6	0,6
Pump Motor	HP	0,75	-	0,75	-
Compressor motor (Mod. with option)	HP	2	2	2	2
Boiler Heater (Mod. with option)	kW	12	-	12	-
CONNECTIONS					
Ø Water inlet	BSP	3/8"	-	3/8"	-
Ø Boiler exhaust (mod. with boiler)	BSP	1/2"	-	1/2"	-
Ø Steam inlet	BSP	-	1/2"	-	1/2"
Ø Condensate outlet	BSP	-	1/2"	-	1/2"
Steam pressure	BAR	4-5	4-5	4-5	4-5
Steam Consumption	Kg/h	12-20	12-20	12-20	12-20
Ø Air inlet	BSP	-	3/8"	-	3/8"
Ø Air pressure	BAR	6-7	6-7	6-7	6-7
Ø Air Consumption	NI/min	40	40	40	40
DIMENSIONS / PACKING DIMENSIONS					
Net width / Gross width	mm	1.370 / 1.440	1.370 / 1.440	1.370 / 1.440	1.370 / 1.440
Net depth / Gross depth	mm	1.080 / 1.110	1.080 / 1.110	1.080 / 1.110	1.080 / 1.110
Net height / Gross height	mm	1.250 / 1.410	1.250 / 1.410	1.250 / 1.410	1.250 / 1.410
Net weight / Gross weight	kg	292 / 342	237 / 287	292 / 342	237 / 287
Volume	m ³	1,84 / 2,25	1,84 / 2,25	1,84 / 2,25	1,84 / 2,25
OTHERS					
Voltage	Hz	230/400V III	230/400V III	230/400V III	230/400V III
Sound level	dB	70	70	70	70

PRESS
WITH BOILER (self-contained)

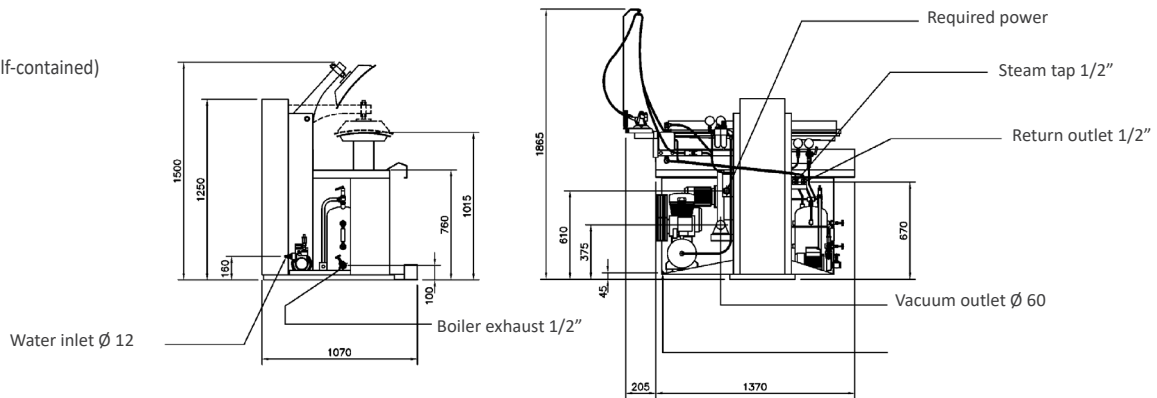

PRESS
WITHOUT BOILER

