



Primer

PN-100/18 - PN-120/18 WALL IRONERS Ø 180 mm



ELECTRONIC PROGRAMMER

Simple and user friendly : start/stop button, selection of 4 temperatures
Preset ironing speeds, not adjustable



EFFICIENCY

Acoustic comfort : <55 dB
Minimum space requirement: space saving, suitable for small spaces
Ideal for processing small quantity of flat linen in facilities like restaurants, guest rooms, hostels...



ROBUSTNESS

Nomex quality coating: resistant to high temperatures
Panels in grey skinplate and stainless steel
Wooden feeding board



FEATURES

Large roll contact area with the linen
Roll lifting control by pedal
Two available models:
Standard: roll with cotton polyester coating
Nomex: roll with Nomex coating



MAINTENANCE

Easy installation : requires only an electrical connection
Easy access on both sides for maintenance



OTHERS

Front feeding and return
Roll Ø 180 mm
Working widths: 1.000 and 1.200 mm
Electric heating
CE certification

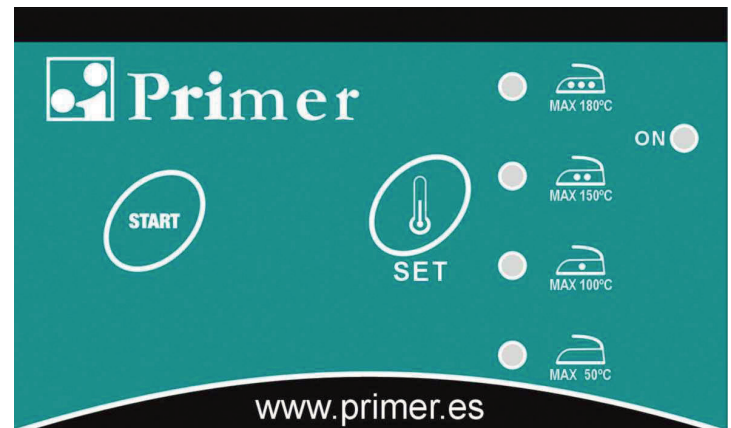

TECHNICAL DATA	UNIT.	PN-100/18	PN-120/18
GENERAL DATA			
Theoretical production*	Kg/h	15	20
Ø Roll	mm	180	180
Working width	mm	1.000	1.200
Ironing speed	mt/min	2,02	2,02
Electronic programmer	-	Yes	Yes
Bed lifting	-	By pedal	By pedal
POWER			
Heating power	Kw	3,3	4
Roll motor power	Kw	0,029	0,029
Total electric power	Kw	3,329	4,029
CONNECTIONS		ELECTRIC	ELECTRIC
Tension 230V - I + N + T	Nº x mm²/A	3 x 4 / 16A	3 x 4 / 20A
Tension 400V - III + N + T	Nº x mm²/A	-	-
OVERALL DIMENSIONS/ PACKING DIMENSIONS			
Net width / Gross width	mm	1.370 / 1.490	1.570 / 1.690
Net depth / Gross depth	mm	438 / 540	438 / 540
Net height / Gross height	mm	952 / 1.130	952 / 1.130
Net weight / Gross weight	Kg	80 / 100	90 / 110
Volume	m³	0,57 / 0,91	0,65 / 1,03
OTHERS			
Noise Level	dB	55	55

*20-25% Theoretical production

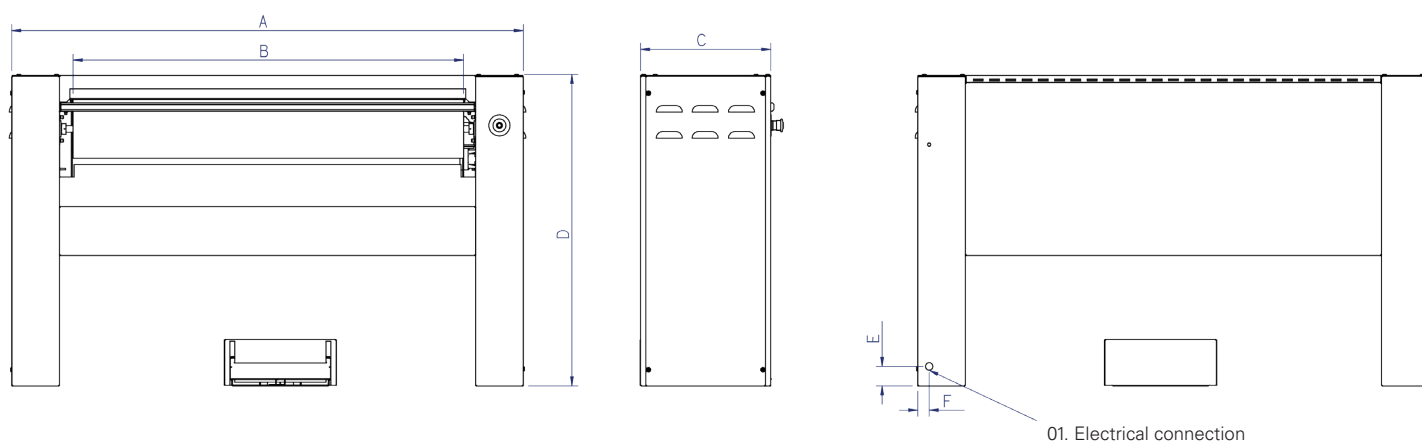

	A	B	C	D	E	F
PN-100/18	1694	1447	689	1354	68	785
PN-120/18	1694	1447	689	1354	68	785

