



Primer

DDS-11/14/18 STANDARD P TUMBLE DRYERS



P PROGRAMMER

New P programmer: push buttons to control temperature and time



OUTSTANDING FEATURES

Reversing drum action as standard
Stainless steel drum as standard
Frequency inverter as standard



EFFICIENCY

DUAL AIRFLOW- New 'optimized' system of mixed airflow
Big fluff filter



VERSATILITY

Make to order - customisation
OPL > Multivending - Standard OPL model easily trasformable to coin laundry uses



ERGONOMICS

Drawer as fluff filter, stainless steel mesh
Biggest door diameters



MAINTENANCE

Hinged control panel: easy and ergonomic access
Technical menu: statistics for technicians and maintenance with external console (with console option)



OTHERS

Grey skinplate outer casing, stainless steel look
Transmission by direct drive
EFFICIENT DRUM- The new drum with stamped holes
COOL DOWN - anti-wrinkle at the end of the cycle
Heating options: electric and gas
CE approved



OPTIONS

- Screen in P programmer (2 units)

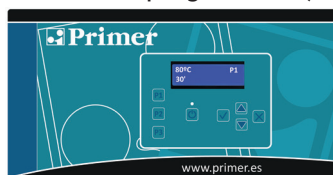

- Double doorglass
- Fluff filter with grid 0,3 mm (standard is 0,6 mm)
- Stainless steel front and side panels
- Front panel in stainless steel
- Maritime wooden packing
- Ship voltage for electric models: 440V III 50/60 Hz No neutral
- Other voltages available

TECHNICAL DATA	UNIT.	DDS -11 P	DDS -14 P	DDS -18 P			
CAPACITY							
Capacity 1/18	Kg	24	30	36			
Capacity 1/20	Kg	22	28	34			
Hourly Output (electr. // gas)	Kg/h	31,6 // 30,6	34,4 // 33,8	36,2 // 36			
Evaporation capacity (electr. // gas)	l/h	15,8 // 15,3	17,2 // 16,9	18,1 // 18			
DRUM							
Ø Drum	mm	750	750	750			
Ø Door	mm	574	574	574			
Door center height	mm	547 / 1.522	547 / 1.522	547 / 1.522			
Load hole bottom height	mm	260 / 1.235	260 / 1.235	260 / 1.235			
Drum length	mm	475	610	746			
Drum volume	l	210	269	330			
POWER							
Drum motor power	kW	0,37 x 2	0,37 x 2	0,37 x 2			
Fan motor power	kW	0,25 x 2	0,25 x 2	0,25 x 2			
Electric heating power	kW	12 x 2	12 x 2	12 x 2			
Total electric power (elec.model)	kW	25,34	25,34	25,34			
Gas heating power	kW	12 x 2	12 x 2	12 x 2			
Instant propane gas consumption (G31)	kg/h	1,03 x 2	1,03 x 2	1,03 x 2			
Instant natural gas consumption (G20)	m3/h	1,27 x 2	1,27 x 2	1,27 x 2			
Total electric power (gas model)	kW	1,34	1,34	1,34			
CONNECTIONS		ELECTRICAL	GAS	ELECTRICAL	GAS	ELECTRICAL	GAS
Tension 230V - I + N + T	Nº x mm2 / A	-	3 x 1,5 / 20A	-	3 x 1,5 / 20A	-	3 x 1,5 / 20A
Tension 230V - III + T	Nº x mm2 / A	4 x 25 / 80A	3 x 1,5 / 20A	4 x 25 / 80A	3 x 1,5 / 20A	4 x 25 / 80A	3 x 1,5 / 20A
Tension 400V - III + N + T	Nº x mm2 / A	5 x 10 / 40A	3 x 1,5 / 20A	5 x 10 / 40A	3 x 1,5 / 20A	5 x 10 / 40A	3 x 1,5 / 20A
Ø Gas inlet	BSP	1/2"		1/2"		1/2"	
DIMENSIONS / PACKING DIMENSIONS							
Net width / Gross width	mm	785 / 865		785 / 865		785 / 865	
Net Depth / Gross Depth	mm	972 / 1.055		1.106 / 1.189		1.242 / 1.325	
Net Height / Gross Height	mm	1.980 / 2.126		1.980 / 2.126		1.980 / 2.126	
Net weight / Gross weight	Kg	260 / 268		275 / 293		290 / 317	
OTHERS							
Max airflow	m3/h	500 x 2		500 x 2		500 x 2	
Ø Fume exhaust	mm	200		200		200	
Sound level	dB	64		64		64	

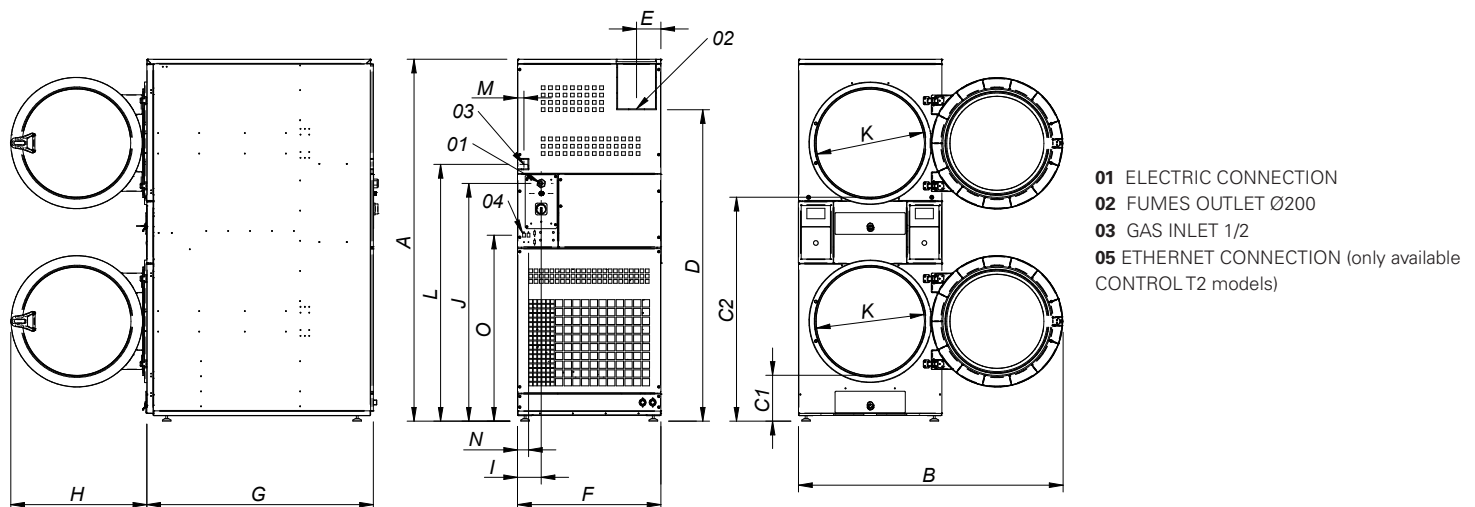

	A	B	C1	C2	D	E	F	G	H	I	J	K	L	M	N	O
DDS-11	1980*	1447	259	1234	1680	135	785	972	735	130	1275	575	1406	35	60	1018
DDS-14	1980*	1447	259	1234	1680	135	785	1106	735	130	1275	575	1406	35	60	1018
DDS-18	1980*	1447	259	1234	1680	135	785	1242	735	130	1275	575	1406	35	60	1018

* Measurement with legs mounted (30mm)

