



Primer

DDL-22 BASIC P TUMBLE DRYERS



P PROGRAMMER

New P programmer: push buttons to control temperature and time



OUTSTANDING FEATURES

Reversing drum action as standard
Frequency inverter as standard



VERSATILITY

Make to order - customisation
OPL > Multivending - Standard OPL model easily transformable to coin laundry uses



ERGONOMICS

Drawer as fluff filter, stainless steel mesh
Biggest door diameters



MAINTENANCE

Hinged control panel: easy and ergonomic access
Technical menu: statistics for technicians and maintenance with external console (with console option)



OTHERS

White painted panels
COOL DOWN - anti-wrinkle at the end of the cycle
Heating options: electric and gas
CE approved

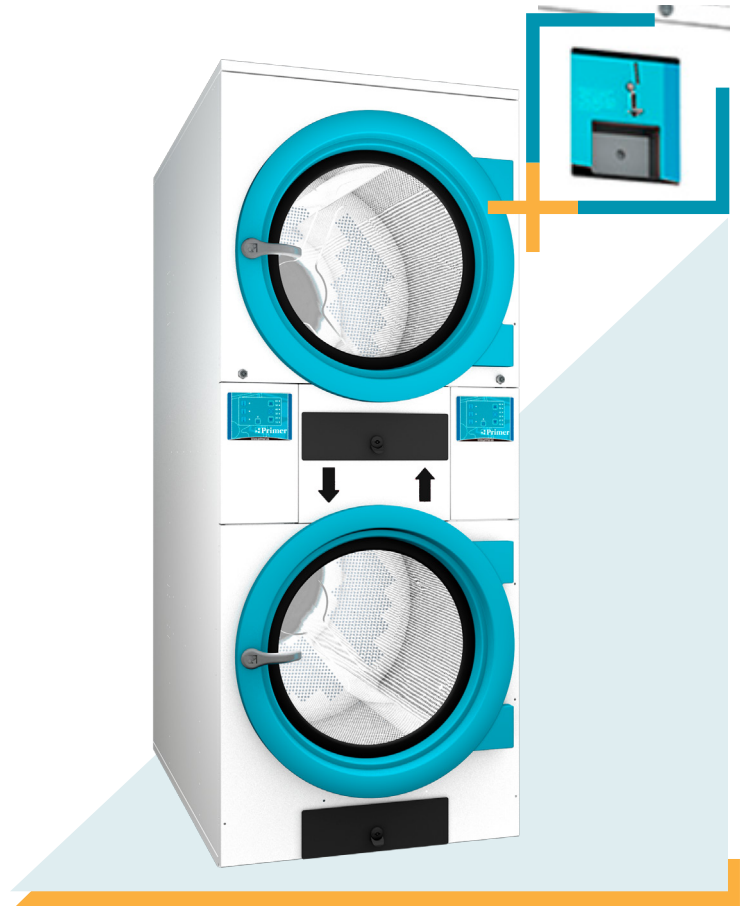

OPTIONS

- Screen in P programmer (2 units)

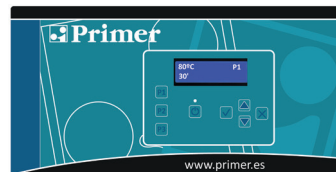

- Fluff filter with grid 0,3 mm (standard is 0,6 mm)
- Ship voltage for electric models: 440V III 50/60 Hz No neutral
- Other voltages available

TECHNICAL DATA	UNIT.	DDL -22 P
CAPACITY		
Capacity 1/18	Kg	48
Capacity 1/20	Kg	44
Hourly Output (gas)	Kg/h	88
Evaporation capacity (gas)	l/h	44
DRUM		
Ø Drum	mm	835
Ø Door	mm	574
Door center height	mm	547 / 1.618
Load hole bottom height	mm	272 / 1.322
Drum length	mm	800
Drum volume	l	438
POWER		
Drum motor power	kW	0,37 x 2
Fan motor power	kW	0,55 x 2
Electric heating power	kW	-
Total electric power (elec.model)	kW	-
Gas heating power	kW	30,4 x 2
Instant propane gas consumption (G31)	kg/h	1,03 x 2
Instant natural gas consumption (G20)	m3/h	1,27 x 2
Total electric power (gas model)	kW	1,94
CONNECTIONS		
		GAS
Tension 230V - I + N + T	Nº x mm2 / A	3 x 1,5 / 20A
Tension 230V - III + T	Nº x mm2 / A	-
Tension 400V - III + N + T	Nº x mm2 / A	-
Ø Gas inlet	BSP	3/4"
DIMENSIONS / PACKING DIMENSIONS		
Net width / Gross width	mm	870 / 950
Net Depth / Gross Depth	mm	1.328 / 1.411
Net Height / Gross Height	mm	2.117 / 2.250
Net weight / Gross weight	Kg	374 / 394
OTHERS		
Max airflow	m3/h	900 x 2
Ø Fume exhaust	mm	250
Sound level	dB	69

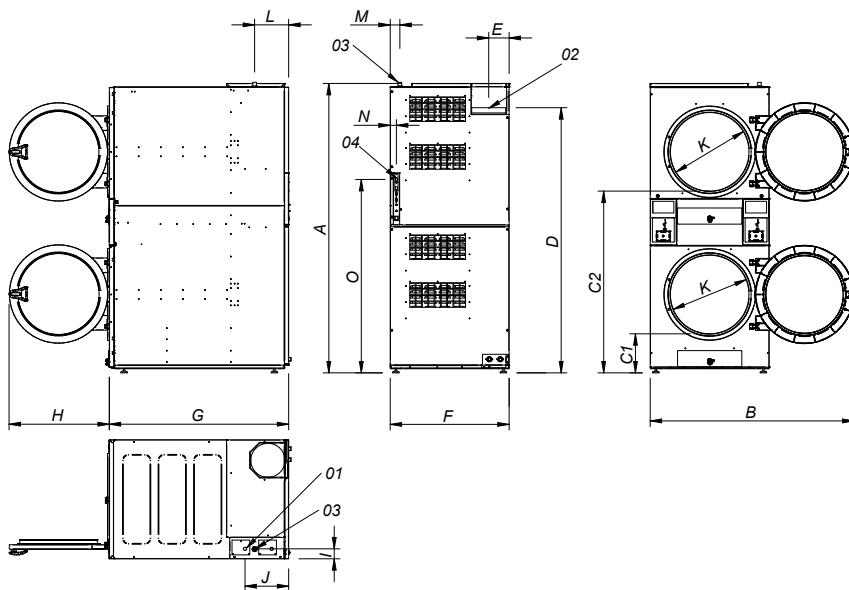

- 01 ELECTRIC CONNECTION
- 02 FUMES OUTLET Ø250
- 03 GAS INLET 3/4
- 04 ETHERNET CONNECTION (only available CONTROL T2 models)

	A	B	C1	C2	D	E	F	G	H	I	J	K	L	M	N	O
DDL -22	2118*	1490	286	1330	1940	149	870	1312	735	73	320	575	250	70	45	1416

* Measurement with legs mounted (30mm)

