



Primer

C-200/32, C-260/32, C330/32 P EXCELLENCE FLATWORK DRYER IRONERS Ø325



ELECTRONIC CONTROL

Simple and user friendly with an auto mode: automatic management of the ironing speed according to the selected temperature. Digital speed and temperature display



EFFICIENCY

Good heat conduction thanks to the roll material and thickness: greater control of energy expenditure
Automatic shutdown at 80°C
Fumes circulation circuit from the bottom reducing energy consumption
Radiant gas burners: 33% more productive



ROBUSTNESS

Roll driving by speed inverter Nomex quality feeding and ironing belts: high temperatures resistant
Panels in skinplate and stainless steel.
Coiled felt for greater lifespan
Nickel plating roll as option: anticorrosive, more durable



ERGONOMICS

Acoustic comfort : <65 dB
Appropriate operating height: 990 mm feeding belts
Minimal encumbrance: space saving, suitable for most spaces
Electronic control with Auto mode: easy to use, optimized ironing speed



MAINTENANCE

Easy access to all components on both sides of the machine
Basic connections : electrical connection and air extraction



OTHERS

Dries and irons flat linen from a high spin washer extractor in a single operation
Front feeding and return
Built-in cool down system
Polished steel roll ø 325 mm
Roll length: 2000, 2600 and 3300 mm
Electric or radiant gas heating
CE standard

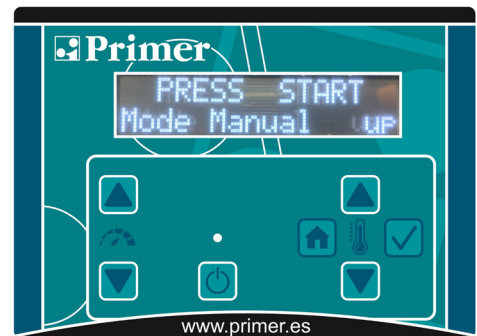
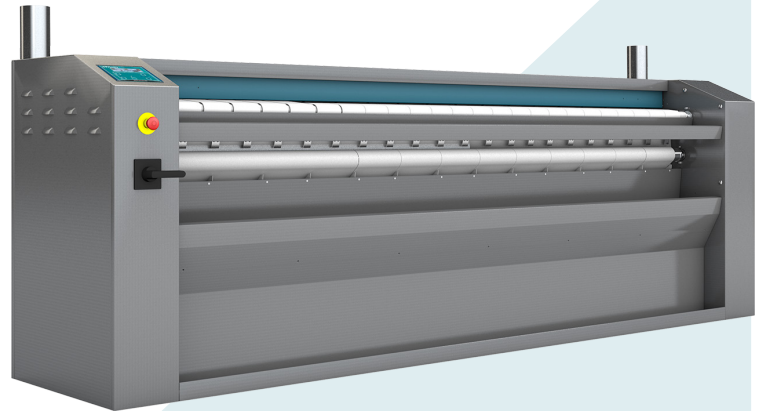

OPTIONS

- IMC: automatic regulation of ironing speed according to residual moisture
- Nickel plate roll
- Tension 440V III 60 Hz without N (electric models)
- Tension 230V III 50-60 Hz

TECHNICAL DATA	UNIT.	C-200/32 P	C-260/32 P	C-330/32 P			
GENERAL DATA							
Theoretical production*	Kg/h	40-50	50-60	75-85			
Atmo. gas theoretical production*	Kg/h	-	-	-			
Radiant gas theoretical production*	Kg/h	60-65	70-75	90-100			
Evaporation power	Kg/h	21-30	23-34	34-45			
Ø Roll	mm	325	325	325			
Working length	mm	2.000	2.600	3.300			
Feeding bands height	mm	990	990	990			
Ironing speed	mt/min	1,5 - 12	1,5 - 12	1,5 - 12			
Electronic control		Yes	Yes	Yes			
No of programs	Nº	2	2	2			
Rear exit + length folder		-	-	-			
POWER							
Electric heating	kW	31,5	40,5	54			
Total electric power (elec. mod.)	kW	32,02	41,02	54,52			
Gas heating	kW	40	55	69			
Total electric power (gas mod.)	kW	0,49	0,52	0,52			
Steam heating	kW	-	-	-			
Total electric power (steam mod.)	kW	-	-	-			
Roll motor	kW	0,37	0,37	0,37			
Fan motor	kW	0,12x2	0,12x2	0,12x2			
Folder add. elec. power	kW	-	-	-			
Folder+rear exit add. elec. power	kW	-	-	-			
CONNECTIONS							
		ELECT / GAS		ELECT / GAS		ELECT / GAS	
Tension 230V - III + T	Nº x mm²/A	4x25 / 100A	4x2,5 / 6A	4x25 / 125A	4x2,5 / 6A	4x35 / 150A	4x2,5 / 6A
Tension 400V - III + N + T	Nº x mm²/A	5x10 / 50A	5x2,5 / 6A	5x16 / 63A	5x2,5 / 6A	5x25 / 100A	5x2,5 / 6A
Ø Gas inlet		1/2"		1/2"		1/2"	
Ø Steam inlet		-		-		-	
Ø condensed (steam model)		-		-		-	
OVERALL DIMENSIONS / PACKING DIMENSIONS							
Net / gross width	mm	2.552 / 2.780		3.202 / 3.430		3.852 / 3.980	
Net / gross depth	mm	686 / 770		686 / 770		686 / 770	
Net / gross height	mm	1.112 / 1.400		1.112 / 1.400		1.112 / 1.400	
Net / gross weight	Kg	435 / 458		545 / 585		655 / 700	
Volume	m³	1,95 / 3,00		2,44 / 3,70		2,94 / 4,29	
OTHERS							
No fume outlet	Nº	2		2		2	
Ø Extraction	mm	98		98		98	
Airflow	m3/h	1000		1000		1000	
Sound level	dB	63		63		63	

*45 % moisture

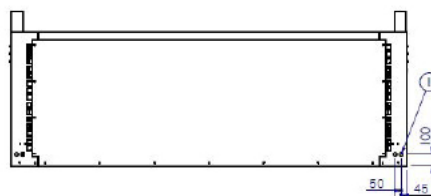
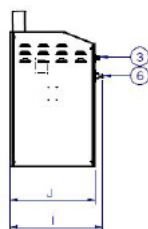
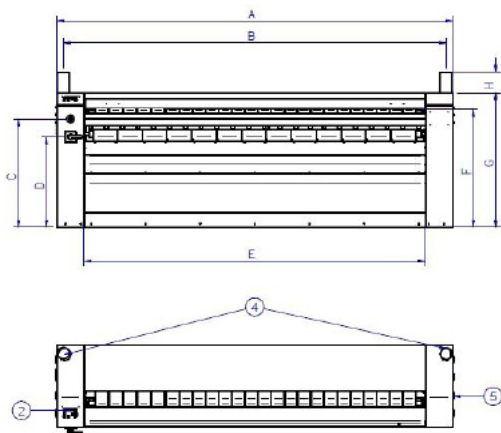

- 01. Electrical connection
- 02. BM Control
- 03. Emergency stop
- 04. ø 98 mm extraction
- 05. Crank
- 06. Main switch

	A	B	C	D	E	F	G	H	I	J
C-200/32 P	2.552	2.446	900	750	2.110	980	1.112	140	746	686
C-260/32 P	3.202	3.096	900	750	2.760	980	1.112	140	746	686
C-330/32 P	3.852	3.746	900	750	3.410	980	1.112	140	746	686

