



Primer

DP-8 / 10 T2

PROFESSIONAL DRYERS



T2 CONTROL

User friendly and totally programmable 7" USB Connection. Online platform free of charge for programming, telemetry, data analysis...thanks to the IoT
Videos on display (ads, instructions, etc.)
37 languages
8 dosing signals as standard



VERSATILITY

OPL <> COIN
Standard models can be programmed as OPL or coin laundry version, central pay, etc.
SINGLE <> STACKED
Models can be stacked on top of a washer or on another dryer. Control panels can be assembled between both drums for better ergonomics.
Ideal for multiple solutions: hotels, hostels, campings, coin laundries, facility services (mops), gyms, etc.
Wet cleaning features



OUTSTANDING FEATURES

Reduced drying times (less than 45 minutes)
6,75 kw heating, option 4,5 kw



CONNECTIVITY

IoT - Primerlink standard.
Management of laundries: OPL and COIN
Remote payment



EFFICIENCY

Optimised airflow
Wide fluff filter as drawer
Efficient design



ROBUSTNESS

Outer casing in grey skinplate
Robust aluminium big door
Industrial fan and powerful airflow
Sturdy construction of the dryer structure and panels



OTHERS

Galvanized drum
Gas or electric heated models
CE approved product



OPTIONS

- SMART DRY Humidity sensor
- Stainless steel outer casing
- AISI 304 stainless steel drum
- Reversing door opening
- Tropicalized model: protected board
- Plinth for better ergonomics
- Plinth for better ergonomics in stainless steel
- Control panel mounted below (stacked dryer)
- Complete container order + compact packing
- Maritime voltage 440V III 50/60 Hz No neutral
- Coin/token kit

TECHNICAL DATA	UNID.	DP-8T2		DP-10T2	
CAPACITY & DRUM					
Capacity 1:20	Kg	8		10	
Volume (litres)	l	160		200	
Drum diameter Ø	mm	590		590	
Drum depth	mm	585		690	
DOOR					
Height center door	mm	554		554	
Height base door	mm	320		320	
Door diameter	mm	480		480	
GENERAL DETAILS					
Microprocessor touch screen 4,3"	-	✓		✓	
USB connection	-	✓		✓	
Construction Panels	-	Skinplate		Skinplate	
Plinth OPT	-	OPT		OPT	
Coin laundry version	-	✓		✓	
Noise level	dB	62		62	
POWER					
Motor / Fan	kW	0,37		0,37	
Electric heating	kW	4,5 / 6,75		4,5 / 6,75	
Gas heating	kW	6,7		6,7	
CONNECTIONS					
		ELECTRIC	GAS / STEAM	ELECTRIC	GAS / STEAM
Tension 230V I+N+T 50Hz / 60Hz	Nº x mm2/A	3 x 10 / 40A	3 x 1,5 / 10A	3 x 10 / 40A	3 x 1,5 / 10A
Tension 230V III+T 50Hz // 60Hz	Nº x mm2/A	4 x 4 / 25A	3 x 1,5 / 10A	4 x 4 / 25A	3 x 1,5 / 10A
Tension 400V III+N+T 50Hz // 60Hz	Nº x mm2/A	5 x 2,5 / 16A	3 x 1,5 / 10A	5 x 2,5 / 16A	3 x 1,5 / 10A
Fume exhaust Ø	mm	100		100	
Maximum airflow	m³/hour	300		300	
CONSUMPTIONS					
Electric heating consumption	kW	6,75 / 4,5		6,75 / 4,5	
Instant propane gas consumption (G31)	kg/h	0,57		0,57	
Instant natural gas consumption (G20)	m³/h	0,71		0,71	
DIMENSIONS / PACKING DIMENSIONS					
Net width / Gross width	mm	680 / 710		680 / 710	
Net Depth / Gross Depth	mm	722 / 832		775 / 832	
Net Height / Gross Height	mm	1056 / 1141		1056 / 1141	
Net weight / Gross weight	kg	89 / 101		93 / 104	
Volume	m³	0,67		0,67	

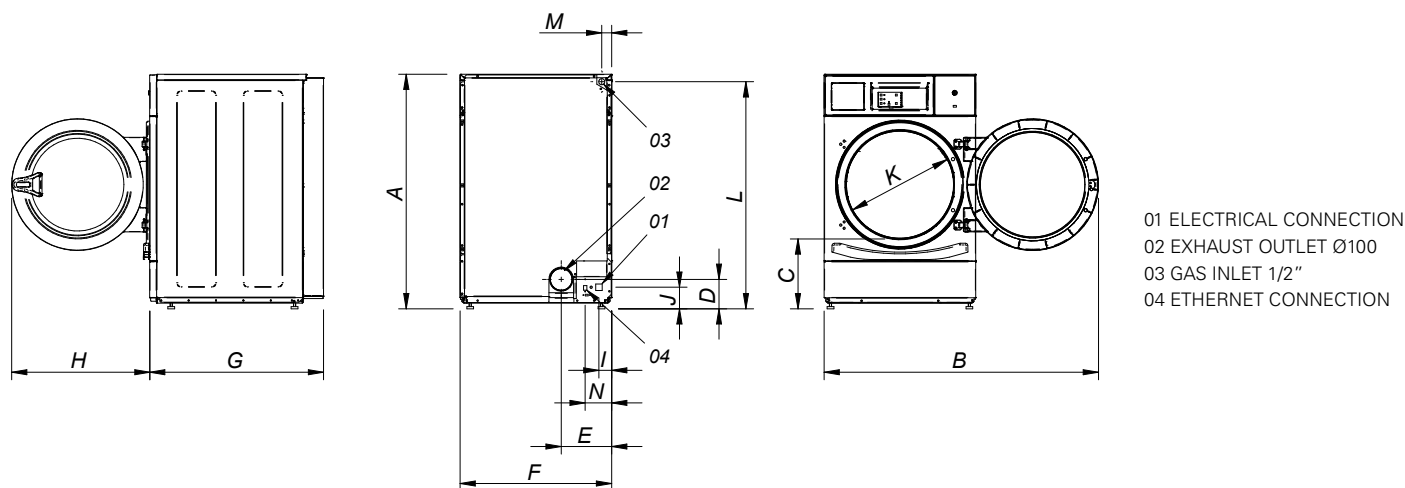

	A	B	C	D	E	F	G	H	I	J	K	L	M	N
DP-8T2	1056	1227	320	140	226	680	722	615	57	91	480	1015	50	118
DP-10T2	1056	1227	320	140	226	680	775	615	57	91	480	1015	50	118

