

## PNEUMATIC PRESSES

### PRE-U / PRE-CP

## FEATURES

TWO MODELS:

- **UNIVERSAL BUCK: PRE-U**
- **BUCK FOR COLLARS AND CUFFS: PRE-CP**

Lower buck with steam in all models.

Upper buck is up-steaming also.

Optional: upper buck with polished head for laundry, without steam then.

Work table dimensions: 1.180 x 380 x 220 mm.

Lowering of the upper buck controlled by two push buttons.

Steam inlet in the upper buck by push button.

Steam inlet in the lower buck by push pedal.

All models equipped with a vacuum unit.

Connection: 230/400V III 50Hz.



PRE-U



PRE-CP

## OPTIONS

- Steam generator- boiler 16 Litres (12 kW).
- Compressor unit. 2 HP.
- Group of iron + pedal.
- Spray gun for steam.
- Polished upper buck for laundry (not up-steaming).

TECHNICAL DATA	UNIT.	PRE-U		PRE-CP	
		WITH BOILER	WITHOUT BOILER	WITH BOILER	WITHOUT BOILER
<b>GENERAL DETAILS</b>					
Board dimensions	mm	1.170 x 360 x 220	1.170 x 360 x 220	940 x 160	940 x 160
Boiler capacity	l	16	-	16	-
Compressor	-	Opt	Opt	Opt	Opt
Group of Iron	-	Opt	Opt	Opt	Opt
Steam gun	-	Opt	Opt	Opt	Opt
Polished upper buck	-	Opt	Opt	Opt	Opt
<b>POWER</b>					
Vacuum Motor	HP	0,6	0,6	0,6	0,6
Pump Motor	HP	0,75	-	0,75	-
Compressor motor (Mod. with option)	HP	2	2	2	2
Boiler Heater	kW	12	-	12	-
<b>CONNECTIONS</b>					
Ø Water inlet	BSP	3/8"	-	3/8"	-
Ø Boiler exhaust (mod. with boiler)	BSP	1/2"	-	1/2"	-
Ø Steam inlet	BSP	-	1/2"	-	1/2"
Ø Condensate outlet	BSP	-	1/2"	-	1/2"
Steam pressure	BAR	4-5	4-5	4-5	4-5
Steam Consumption	Kg/h	12-20	12-20	12-20	12-20
Ø Air inlet	BSP	-	3/8"	-	3/8"
Ø Air pressure	BAR	6-7	6-7	6-7	6-7
Ø Air Consumption	Nl/m	40	40	40	40
<b>DIMENSIONS / PACKING DIMENSIONS</b>					
Width / Width	mm	1.370/1.440	1.370/1.440	1.370/1.440	1.370/1.440
Depth / Depth	mm	1.080/1.110	1.080/1.110	1.080/1.110	1.080/1.110
Height / Height	mm	1.250/1.410	1.250/1.410	1.250/1.410	1.250/1.410
Net weight / Gross weight	kg	292/342	237/287	292/342	237/287
Gross volume	m <sup>3</sup>	2,25	2,25	2,25	2,25
<b>OTHERS</b>					
Voltage	Hz	230/400V III 50	230/400V III 50	230/400V III 50	230/400V III 50
Sound level	dB	70	70	70	70

PRE-U / PRE-CP  
WITH BOILER (AUTONOMOUS)

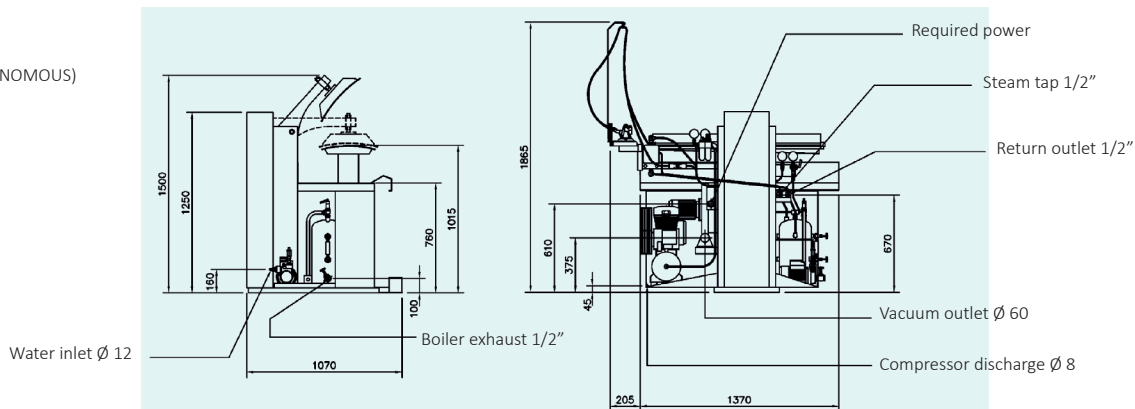

PRE-U / PRE-CP  
WITHOUT BOILER

